

Packing List			
Mark	Model	Description	Qty
		Screws	10
BI	B34	Sink Base w/ Doors Left Sink	1
CI	B34s	Work Surface w/ Left Sink	1
PI		Door/Drawer Pull	6
UI	U31	Upper Dispense Cabinet	1

Backers	
Description	Length
2x6 Backer	4' - 7 3/32"
2x6 Backer	4' - 7 3/32"
2x6 Backer	2' - 4 3/16"
2x6 Backer	4' - 7 5/32"
	16' - 1 17/32"

Utilities		
Mark	Description	Qty
H	Hot Water Supply	1
C	Cold Water Supply	1
D	Sanitary DWV	1

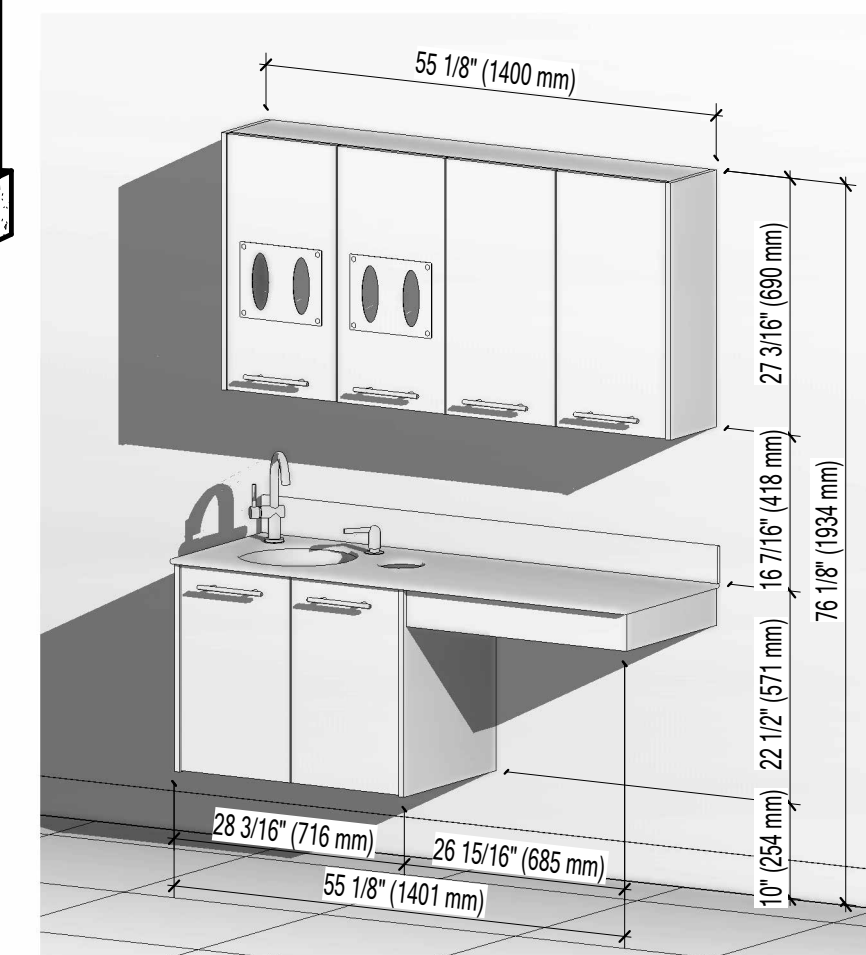
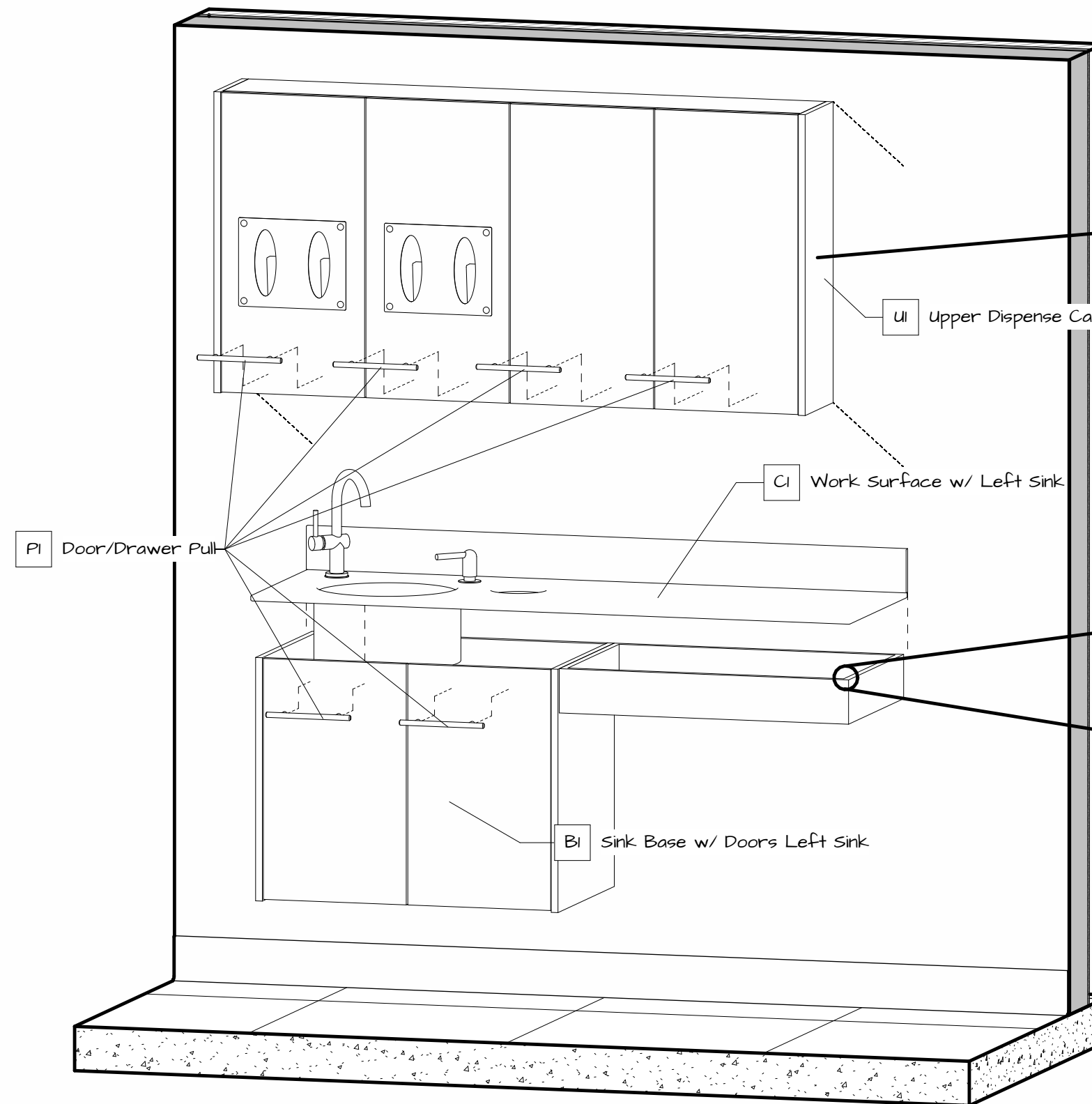
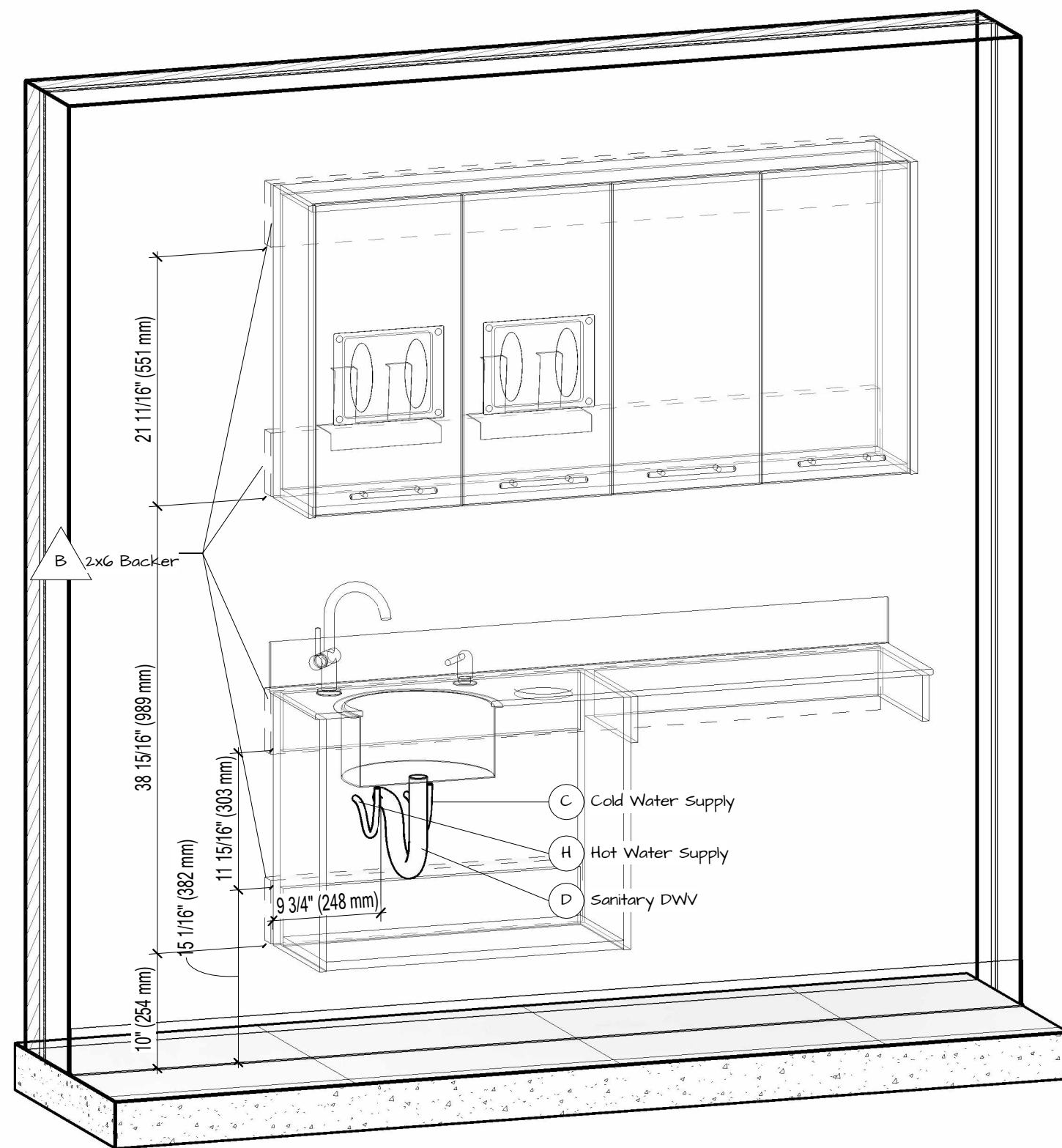

NOVA Solutions Inc.
217-342-7070
sales@novasolutionsinc.com

Installation Drawing	
Title	ALSTC B34-H00-U33
Date	4/26/2024
Drawn by	Justin Martin